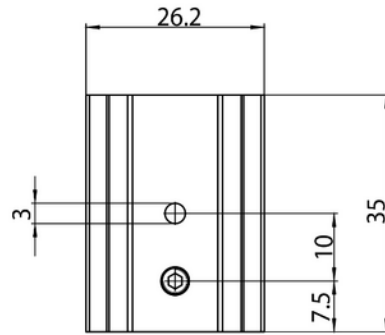

**PRODUCT DATA SHEET**

Track EVO 48V ST1 short pendant bracket for suspensions WH

Art.no: 9500-312-SV-3

*Lighting Solutions*

Track EVO 48V ST1 short pendant bracket for suspensions WH



White short bracket for wire installation

TECHNICAL DATA	
Outdoor	No

DIMENSIONS	
Length (product) (mm)	35.0
Width (product) (mm)	26.2
Height (product) (mm)	10.4

MATERIALS AND SURFACES	
Color	White
RAL Code	RAL9016
Housing Material	Aluminium



PRODUCT DATA SHEET

Track EVO 48V ST1 short pendant bracket for suspensions WH

Art.no: 9500-312-SV-3



Lighting Solutions

ENERGY AND CERTIFICATIONS	
CE mark	Yes